

THE INFORMATION CONTAINED HEREON IS THE PROPERTY OF PENTAIR WATER POOL & SPA INC. NO PORTION OF THIS DATA SHALL BE RELEASED, DISCLOSED, USED, OR DUPLICATED FOR USE IN PROCUREMENT OR MANUFACTURING WITHOUT SPECIFIC WRITTEN PERMISSION FROM PENTAIR WATER POOL & SPA INC.

REVISIONS

PCO	REV	DESCRIPTION	DATE	DRWN	CHKD
16811	B	THE COPY RIGHT WAS INCORRECT AND HAS BEEN UPDATED.	2/28/08	RP	

COMPUTER GENERATED DOCUMENT
MANUAL CHANGES NOT ALLOWED.

5 THE SOLID GEOMETRIC MODEL ASSOCIATED WITH THE DRAWING MUST BE CONSIDERED A PART OF THE SPECIFICATION FOR THE PART AND MUST BE REFERED TO FOR FEATURES THAT CANNOT BE DETERMINED BY DIMENSIONS ON THE DRAWING. THIS DRAWING IS TO CONFORM TO SOLIDWORKS GEOMETRY MODEL: S771

4 DIAMOND SYMBOL  DENOTES LAST CHANGE

3 STAR SYMBOL  DENOTES CRITICAL DIMENSION

2 INTERPRET DIMENSIONS AND TOLERANCING IN ACCORDANCE WITH ASME Y14.5-1999

1 MATERIAL:

NOTES: UNLESS OTHERWISE SPECIFIED.

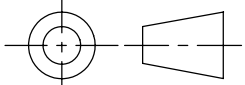
UNLESS OTHERWISE SPECIFIED: DIMENSIONS ARE IN INCHES TOLERANCES: .X OR X/X ± 1/64 .XX ± .01 .XXX ± .005 ANGULAR ± 1° $\sqrt{63}$ SURFACE FINISH REMOVE ALL BURRS & BREAK SHARP EDGES .010 MAXIMUM EXCEPT AT P/L & SHUT OFFS ALL DIAMETERS TO BE CONCENTRIC WITHIN .005 T.I.R.	DO NOT SCALE DRAWING			1620 HAWKINS AVE. SANFORD, NC 27330	
	SIGNATURES	DATE		TITLE	
	DRAWN R PERALTA	2/28/08	<p style="text-align: center;">DYNA-PRO OWNERS MANUAL</p>		
	CHKD				
	SEE PCO FOR APPROVAL SIGNATURES		SIZE A	DWG. NO. S771	REV. B
THIRD ANGLE PROJECTION 			SCALE 1:1	SHEET 1 OF 17	

Technical Support

Sanford, North Carolina (8 A.M to 5 P.M.)

Phone: (800) 831-7133

Moorpark, California (8 A.M to 5 P.M.)

Phone: (800) 831-7133

Fax: (800) 284-4151

Websites: visit www.pentairpool.com and staritepool.com

**© 2008 Pentair Water Pool and Spa, Inc. All rights reserved.
This document is subject to change without notice.**

1620 Hawkins Ave., Sanford, NC 27330 • (919) 566-8000
10951 West Los Angeles Ave., Moorpark, CA 93021 • (805) 553-5000

Trademarks and disclaimers: Sta-Rite® and Dyna-Pro™ are trademarks and/or registered trademarks of Pentair Water Pool and Spa, Inc. and/or its affiliated companies in the United States and/or other countries. Teflon® is a registered trademark of E.I. Du Pont De Nemours and Company Corporation and Plasto-Joint Stik® is a registered trademark of La-Co Industries, Inc. Unless noted, names and brands of others that may be used in this document are not used to indicate an affiliation or endorsement between the proprietors of these names and brands and Pentair Water Pool and Spa, Inc. Those names and brands may be the trademarks or registered trademarks of those parties or others.

'MPRA', 'MPEA' & 'MPE' SERIES PUMPS WITH TRAP

To avoid unneeded service calls, prevent possible injuries, and get the most out of your pump, READ THIS MANUAL CAREFULLY!

The Sta-Rite 'MPRA', 'MPEA' & 'MPE' Series Self-priming Centrifugal pump:

- Is designed for use with swimming pools or as a centrifugal pump.
- Is an excellent performer; durable, reliable.

Table of Contents

Safety Instructions	3-4
Installation.....	4-5
Pool Pump Suction Requirements	6-6
Electrical	6-8
Operation	9
Storage/Winterizing	9-10
Pump Service	10-11
Troubleshooting Guide	12
Repair Parts List	13-14

READ AND FOLLOW SAFETY INSTRUCTIONS!

⚠ This is the safety alert symbol. When you see this symbol on your system or in this manual, look for one of the following signal words and be alert to the potential for personal injury.

⚠ DANGER warns about hazards that **will** cause death, serious personal injury, or major property damage if ignored.

⚠ WARNING warns about hazards that **can** cause death, serious personal injury, or major property damage if ignored.

⚠ CAUTION warns about hazards that **will** or **can** cause minor personal injury or property damage if ignored.

NOTICE indicates special instructions not related to hazards.

Carefully read and follow all safety instructions in this manual and on equipment. Keep safety labels in good condition; replace if missing or damaged.

⚠ WARNING **Hazardous pressure** **Incorrectly installed or tested equipment may fail, causing severe injury or property damage.**

Read and follow instructions in owner's manual when installing and operating equipment. Have a trained pool professional perform all pressure tests.

Single Speed Models		
HP	MPRA	MPE, MPEA
1/2		MPE6C-204L
3/4	MPRA6D-204L	MPEA6D-204L, MPE6D-205L
1	MPRA6E-205L	MPEA6E-205L, MPE6E-206L
1-1/2	MPRA6F-206L	MPEA6F-206L, MPE6F-207L
2	MPRA6G-207L	MPEA6G-207L, MPE6G-208L
2-1/2		MPEAA6G-208L
Two Speed Models		
HP	MPRA	MPE, MPEA
1-1/2	MPRA6YF-206L	MPE6YF-207L
2		MPEA6YG-207L, MPE6YG-208L
2-1/2		MPEAA6YG-208L

1. Do not connect system to a high pressure or city water system.
2. Use equipment only in a pool or spa installation.
3. Trapped air in system can cause explosion. BE SURE all air is out of system before operating or testing equipment.

Before pressure testing, make the following safety checks:

- Check all clamps, bolts, lids, and system accessories before testing.
- Release all air in system before testing.
- Water pressure for test must be less than 25 PSI (7.5 kg/cm²).
- Water Temperature for test must be less than 100° F. (38° C).
- Limit test to 24 hours. After test, visually check system to be sure it is ready for operation. Remove trap lid and retighten hand tight only, see Figure 1.

NOTICE: These parameters apply to Sta-Rite equipment only. For non-Sta-Rite equipment, consult manufacturer.

NOTICE: Do not start the pump until the strainer basket cover is on and the tab, or rib, on the discharge port aligns between the arrows.

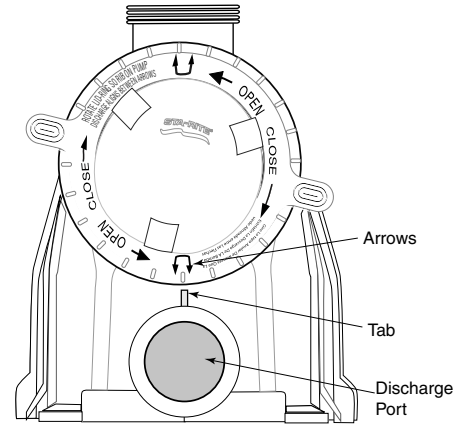

Figure 1 – Strainer basket cover alignment.

INSTALLATION

Only qualified, licensed personnel should install pump and wiring.

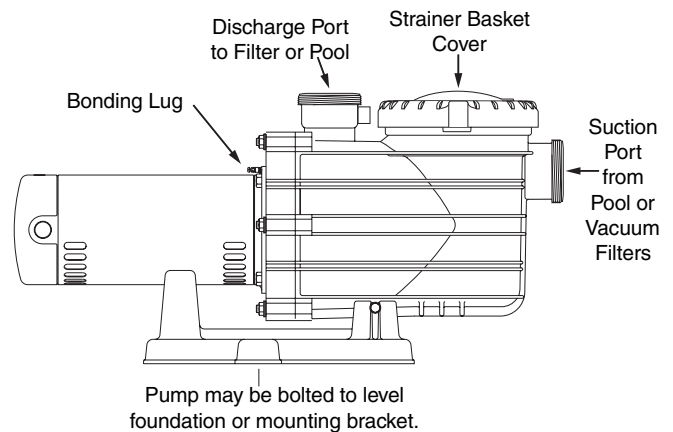

Figure 2

NOTICE: Port threads are: Internal - 2" NPT for direct connection to pipe. External - 3-1/4" Buttress. Fits Sta-Rite U11-200P Union Collar for quick disconnect pipe connection.

See Page 13 for Union Kits.

IMPORTANT SAFETY INSTRUCTIONS

Always follow basic safety precautions with this equipment, including the following.

▲ WARNING To reduce the risk of injury, do not permit children to use this product unless they are closely supervised at all times.

▲ CAUTION This pump is for use with permanently installed pools and may also be used with hot tubs and spas if so marked. Do not use with storable pools. A permanently installed pool is constructed in or on the ground or in a building such that it cannot be readily disassembled for storage. A storable pool is constructed so that it may be readily disassembled for storage and reassembled to its original integrity.

SAVE THESE INSTRUCTIONS

Pump mount must:

Be located away from corrosive or flammable liquids.
 Have enough ventilation to maintain air temperature at less than the maximum ambient temperature rating (Max. Amb.) listed on the motor model plate. If this pump is installed in an enclosure/pump house, the enclosure must have adequate ventilation and air circulation to keep the temperature in the enclosure at or below the motor's rated ambient temperature whenever the pump is running.
 Be solid - Level - Rigid - Vibration free. (To reduce vibration and pipe stress, bolt pump to mount.)

Allow pump suction inlet height to be as close to water level as possible. Pump will not lift water more than 10' (3m).

Allow use of short, direct suction pipe (To reduce friction losses).

Allow for gate valves in suction and discharge piping.

Have adequate floor drainage to prevent flooding.

Be protected from excess moisture.

Allow adequate access for servicing pump and piping.

▲WARNING **Fire and burn hazard.** Modern motors run at high temperatures. To reduce the risk of fire, do not allow leaves, debris, or foreign matter to collect around the pump motor. To avoid burns when handling the motor, let it cool for 20 minutes before trying to work on it.

NOTICE: When connecting threaded pipe directly to pump, use Teflon® tape or Plasto-Joint Stik® to seal connections. Do not use pipe dope; pipe dope causes cracking in some plastics and may damage components in piping system.

When connecting pipe to pump with union half, use Teflon® tape or Plasto-Joint Stik® between pipe and union adapter. Union collar to pump should be assembled dry and hand-tight.

NOTICE: Pump suction and discharge connections have molded in thread stops. DO NOT try to screw pipe in beyond these stops.

Teflon® Taping Instructions:

Use only new or clean PVC pipe fittings.

Wrap male pipe threads with one to two layers of Teflon® tape. Cover entire threaded portion of pipe.

Do not overtighten or tighten past thread stop in pump port! If leaks occur, remove pipe, clean off old tape, rewrap with one to two additional layers of tape and remake the connection.

NOTICE: Support all piping connected with pump!

Piping:

Use at least 2" (51mm) pipe. Increase size if a long run is needed.

To avoid strains on the pump, support both suction and discharge pipes independently. Place these supports near the pump.

To avoid a strain left by a gap at the last connection, start all piping at the pump and run pipe **away** from the pump.

To avoid airlocking, slope suction pipe slightly upward toward the pump.

NOTICE: To prevent flooding when removing pump for service, all flooded suction systems **must** have gate valves in suction and discharge pipes.

POOL PUMP SUCTION REQUIREMENTS



▲ Pump suction is hazardous and can trap and drown or disembowel bathers. Do not use or operate swimming pools, spas, or hot tubs if a suction outlet cover is missing, broken, or loose. Follow the guidelines below for a pump installation which minimizes risk to users of pools, spas, and hot tubs.

Entrapment Protection

The pump suction system *must* provide protection against the hazard of

suction entrapment or hair entrapment/entanglement.

Suction Outlet Covers

All suction outlet covers must be maintained. They must be replaced if cracked, broken, or missing.

See Page 6 for outlet cover certification requirements.

All suction outlets must have correctly installed, screw-fastened covers in place.

Suction Outlets Per Pump (Figure 3, Page 6)

Provide at least two hydraulically balanced main drains, with covers, as suction outlets for each circulating pump suction line. The centers of the main drains (suction outlets) on any one suction line must be at least three feet apart.

The system must be built so that it cannot operate with the pump drawing water from only *one* main drain (that is, there must be at least two main drains connected to the pump whenever it is running – see Figure 3, Page 6). However, if two main drains run into a single suction line, the single suction line may be equipped with a valve which will shut off *both* main drains from the pump (see Figure 3).

More than one pump can be connected to a single suction line as long as the requirements above are met.

Water Velocity

The maximum water velocity through the suction fitting or cover for any suction outlet must not exceed 1.5 feet per second unless the outlet complies with the latest ANSI/ASME Specification for *Suction Fittings For Use in Swimming Pools, Spas, Hot Tubs, and Whirlpool Bathtub Applications*. In any case, do not exceed the suction fitting's maximum designed flow rate.

If 100% of the pump's flow comes from the main drain system, the maximum water velocity in the pump suction hydraulic system must be six feet per second or less even if one main drain (suction outlet) is completely blocked. The flow through the remaining main drain(s) must comply with the latest ANSI/ASME Specification for *Suction Fittings For Use in Swimming Pools, Spas, Hot Tubs, and Whirlpool Bathtub Applications*.

Testing and Certification

Suction outlet covers must have been tested by a nationally recognized testing laboratory and found to comply with the latest ANSI/ASME Specifications for *Suction Fittings For Use in Swimming Pools, Spas, Hot Tubs, and Whirlpool Bathtub Applications*.

Fittings:

Fittings restrict flow; for best efficiency use fewest possible fittings (but at least two suction outlets).

Avoid fittings which could cause an air trap.

Pool fittings must conform to International Association of Plumbing and Mechanical Officials (IAPMO) standards.

Use only non-entrapping suction fitting or double suction.

ELECTRICAL



⚠ Ground motor before connecting to electrical power supply. Failure to ground motor can cause severe or fatal electrical shock hazard.

⚠ Do not ground to a gas supply line.

⚠ To avoid dangerous or fatal electrical shock, turn OFF power to motor before working on electrical connections.

⚠ Ground Fault Circuit Interrupter (GFCI) tripping indicates an electrical problem. If GFCI trips and will not reset, have a qualified

electrician inspect and repair electrical system.

⚠ Exactly match supply voltage to nameplate voltage. Incorrect voltage can cause fire or seriously damage motor and voids warranty. If in doubt consult a licensed electrician.

Voltage

Voltage at motor must be not more than 10% above or below motor nameplate rated voltage or motor may overheat, causing overload tripping and reduced component life. If voltage is less than 90% or more than 110% of rated voltage when motor is running at full load, consult power company.

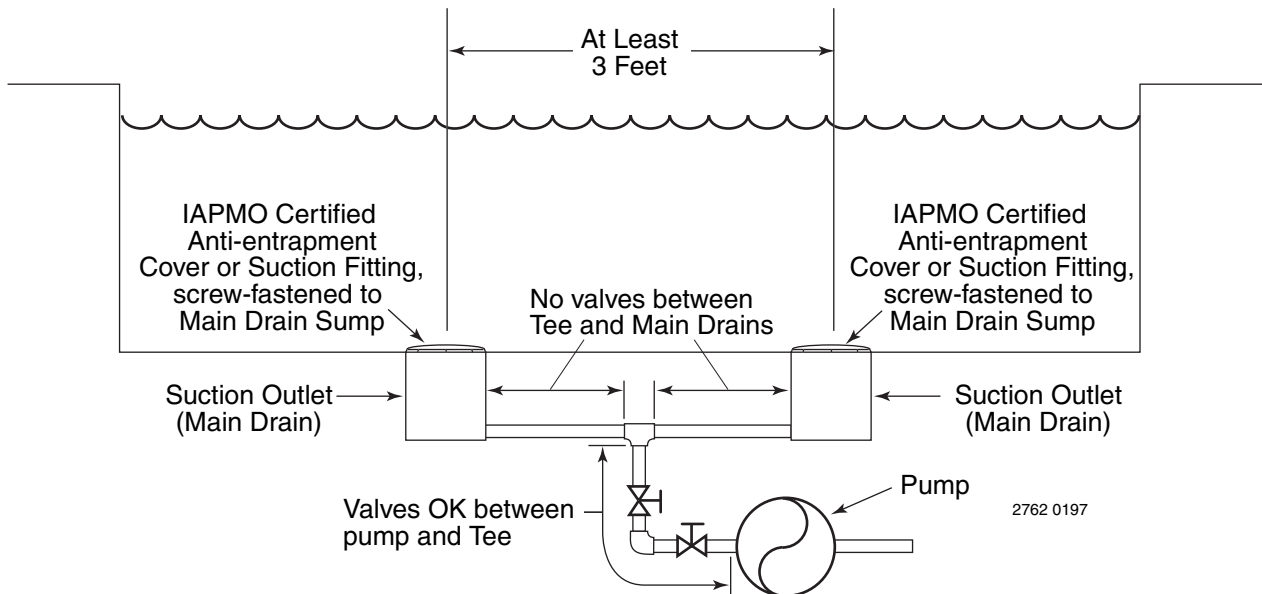

Figure 3 – Recommended pump suction layout.

Grounding/Bonding

Install, ground, bond and wire motor according to local or National Electrical Code requirements.

Permanently ground motor. Use green ground terminal provided under motor canopy or access plate (See Figure 4); use size and type wire required by code. Connect motor ground terminal to electrical service ground.

Bond motor to pool structure. Use a solid copper conductor, size No. 8 AWG (8.4 sq.mm) or larger. Run wire from external bonding lug (see Figure 4) to reinforcing rod or mesh.

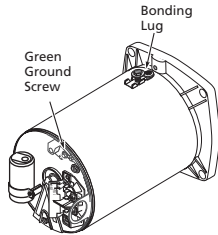

Figure 4 – Typical ground screw and bonding lug locations.

Connect a No. 8 AWG (8.4 sq.mm) solid copper bonding wire to the pressure wire connector provided on the motor housing and to all metal parts of the swimming pool, spa, or hot tub and to all electrical equipment, metal piping or conduit within 5 feet (1.5 m) of the inside walls of swimming pool, spa, or hot tub.

Wiring

NOTICE: 3 phase models require magnetic motor starters and external overload protection. If in doubt about the procedure, consult a licensed electrician.

Pump must be permanently connected to circuit. Table I, Page 8, give correct wire and circuit breaker sizes for the pump alone. If other lights or appliances are also on the same circuit, be sure to add their amp loads to pump amp load before figuring wire and circuit breaker sizes. (If unsure how to do this or if this is confusing, consult a licensed electrician.) Use the load circuit breaker as the master on-off switch.

Install a Ground Fault Circuit Interrupter (GFCI) in circuit; it will sense a short-circuit to ground and disconnect power before it becomes dangerous to pool users. For size of GFCI required and test procedures for GFCI, see manufacturer's instruction.

In case of power outage, check GFCI for tripping (which will prevent normal pump operation). Reset if necessary.

NOTICE: If you do not use conduit when wiring motor, **be sure** to seal wire opening on end of motor to prevent dirt, bugs, etc., from entering.

⚠️ WARNING Risk of dangerous or fatal electrical shock.

Be sure that power to the motor circuit is off before working on wiring, wiring connections, or motor. Re-install the motor end cover and all other wiring covers before turning on the power.

1. Turn off power.
2. Remove the motor end cover.

To Wire a Single Speed, Single Voltage Motor

There are two terminals labeled L1 and L2. Attach the power leads to these terminals. Either wire may attach to either terminal.

To Wire a Dual-Voltage Motor

Dual voltage motors have a plug to change from 230 volts (factory setting) to 115 volts.

1. If you have 230 volts motor supply voltage, confirm that the plug is set for 230 volts. The arrow on the plug will point to the 230 volt position. Note that plug only connects with one prong in this position.
2. If you have 115 volt supply, pull the plug straight up and place it on the **two** brass prongs as shown.



Figure 5A -Voltage Change Plug Set for 230 Volts

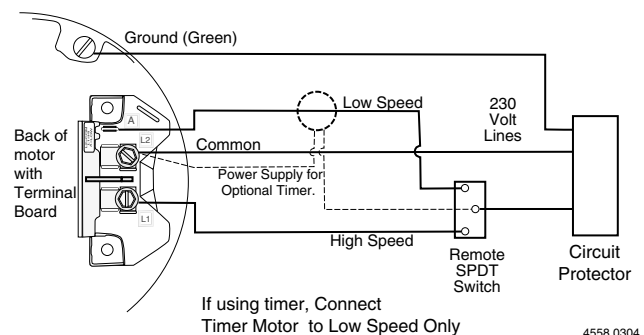

Figure 5B -Voltage Change Plug Set for 115 Volts

NOTE: Arrow is highlighted for clarity.

To Wire a Two-Speed Motor

Wire the pump as shown in the diagram.



Minimum switch and timer amp rating must equal Branch Fuse Rating given in "Recommended Fusing and Wiring Data" table.

Figure 5C: 2-Speed Motor Wiring Diagram

TABLE I - RECOMMENDED CIRCUIT BREAKER AND WIRING DATA

Motor HP	Branch CB Rating Amps	Max Load Amps	Voltage/ Hz/Phase	Serv. to Motor - Dist. in Ft. (M)			AWG Wire Size (mm ²)
				0-100' (0-30)	101-200' (30-60)	201-300' (60-90)	
MPRA SERIES – SINGLE SPEED							
3/4	20/15	13.4/6.7	115/230/60/1	12/14(3/2)	10/14(5.5/2)	8/14(8.4/2)	}
1	20/15	15.3/7.6	115/230/60/1	12/14(3/2)	8/14(8.4/2)	6/14(14/2)	
1-1/2	25/15	19.2/9.6	115/230/60/1	10/14(5.5/2)	8/14(8.4/2)	6/12(14/3)	
2	20	12.0	230/60/1	14(2)	14(2)	12(3)	
MPEA SERIES – SINGLE SPEED							
3/4	15/15	11.0/5.5	115/230/60/1	14/14(2/2)	10/14(5.5/2)	8/14(8.4/2)	}
1	20/15	13.8/6.9	115/230/60/1	12/14(3/2)	10/14(5.5/2)	8/14(8.4/2)	
1-1/2	25/15	16.0/8.0	115/230/60/1	12/14(3/2)	8/14(8.4/2)	6/14(14/2)	
2	15	10.4	230/60/1	14(2)	14(2)	12(3)	
2-1/2	15	11.2	230/60/1	14(2)	14(2)	12(3)	
MPRA SERIES – TWO SPEED							
1-1/2 – 1/4	15	9.2/2.5	230/60/1	14(2)	14(2)	12(3)	}
MPEA SERIES – TWO SPEED							
2 – 1/4	15	10.0/3.0	230/60/1	14(2)	14(2)	12(3)	}
2-1/2 – 1/2	15	11.3/3.3	230/60/1	14(2)	12(3)	12(3)	
MPE SERIES – SINGLE SPEED							
1/2	15/15	11.0/5.5	115/230/60/1	14/14(2/2)	10/14(5.5/2)	8/14(8.4/2)	}
3/4	20/15	13.8/6.9	115/230/60/1	12/14(3/2)	10/14(5.5/2)	8/14(8.4/2)	
1	25/15	16.0/8.0	115/230/60/1	12/14(3/2)	8/14(8.4/2)	6/14(14/2)	
1-1/2	15	10.4	230/60/1	14(2)	14(2)	12(3)	
2	15	11.2	230/60/1	14(2)	14(2)	12(3)	
MPE SERIES – TWO SPEED							
1-1/2 – 1/4	15	10.0/3.0	230/60/1	14(2)	14(2)	12(3)	}
2 – 1/3	15	11.3/3.3	230/60/1	14(2)	12(3)	12(3)	

OPERATION

NOTICE: NEVER run pump dry. Running pump dry may damage seals, causing leakage and flooding. Fill pump with water before starting motor.

⚠ WARNING Before removing trap cover:

1. STOP PUMP before proceeding.
2. CLOSE GATE VALVES in suction and discharge pipes.
3. RELEASE ALL PRESSURE from pump and piping system.

⚠ If pump is being pressure tested, be sure pressure has been released before removing trap cover.

⚠ WARNING

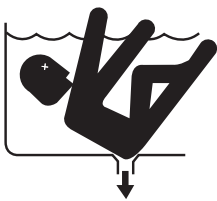

Hazardous suction. Can trap hair or body parts, causing severe injury or death.

Do not block suction.

⚠ Do not block pump suction. To do so with body may cause severe or fatal injury. Small children using pool must ALWAYS have close adult supervision.

⚠ WARNING Fire and burn hazard. Modern motors run at high temperatures. To reduce the risk of fire, do not allow leaves, debris, or foreign matter to collect around the pump motor. To avoid burns when handling the motor, let it cool for 20 minutes before trying to work on it. An automatic internal cutoff switch protects the motor from heat damage during operation.

NOTICE: Maximum ambient temperature for motor operation must not exceed maximum ambient temperature on motor nameplate.

Priming Pump

Release all pressure from filter, pump, and piping system; see the filter owner's manual.

In a flooded suction system (water source higher than pump), pump will prime itself when suction and discharge valves are opened.

If pump is not in a flooded suction system, unscrew and remove trap cover; fill trap and pump with water.

Clean and inspect O-Ring; reinstall on trap groove.

Do not lubricate the trap cover O-Ring. The original equipment O-Ring contains a permanent internal lubricant.

NOTICE: If you replace the O-Ring with a non-internally lubricated O-Ring, you may need to apply a silicone based lubricant.

Replace trap cover on trap; turn clockwise to tighten cover.

NOTICE: Tighten trap cover handle ring by hand only (**no wrenches**)! See Figure 1, Page 4.

Pump should prime now. Priming time will depend on vertical length of suction lift and horizontal length of suction piping.

If pump does not prime, make sure that all valves are open, suction pipe end is under water, pump is not trying to lift water more than 10' (3m), and that there are no leaks in suction pipe. See Troubleshooting Guide, Page 12.

Routine Maintenance

The only routine maintenance needed is inspection/cleaning of trap basket. Debris or trash that collects in basket will choke off water flow through the pump. Follow instructions below to clean trap:

1. Stop pump, close valves in suction and discharge, and **release all pressure from system before proceeding.**
2. Remove trap cover handle ring (turn counterclockwise). If necessary, tap handles gently with a rubber mallet.
3. Remove strainer basket and clean. Be sure all holes in basket are clear, flush basket with water and replace in trap with large opening at pipe connection port (between ribs provided). If basket is replaced backwards cover will not fit on trap body.
4. Clean and inspect lid O-Ring; reinstall on trap groove.
5. Clean O-Ring groove on trap body and replace cover and handle ring. To help keep cover from sticking, tighten **hand tight only.**
6. Prime pump (see priming instructions).

Storage/Winterizing

NOTICE: Allowing pump to freeze will damage pump and void warranty!

NOTICE: Do not use anti-freeze solutions (except propylene glycol) in your pool/spa system. Propylene glycol, "RV antifreeze", is non-toxic and will not damage plastic system components; other anti-freezes are highly toxic and may damage plastic components in the system.

Drain all water from pump and piping when expecting freezing temperatures or when storing pump for a long time (see instructions below).

Keep motor dry and covered during storage.

To avoid condensation/corrosion problems, **do not** cover pump with plastic.

For outdoor/unprotected installations:

1. Enclose entire system in a weatherproof enclosure.
2. To avoid condensation/corrosion damage, allow ventilation; **do not** wrap system in plastic.
3. Use a 40% propylene glycol/60% water solution to protect pump to -50°F (-46°C).

Draining Pump

⚠ WARNING Explosion hazard. Purging the system with compressed air can cause components to explode, with risk of severe injury or death to anyone nearby. Use only a low pressure (below 5 PSI), high volume blower when air purging the pump, filter, or piping.

1. Pump down water level below all inlets to the pool.

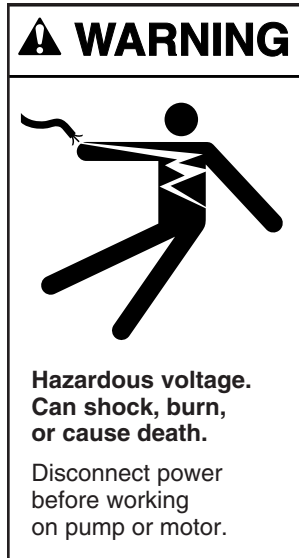

⚠ To avoid dangerous or fatal electrical shock hazard, turn OFF power to motor before draining pump.

2. Remove trap cover handle ring (turn counterclockwise). If necessary, tap handles gently with a rubber mallet. Low pressure air can be used to remove remaining water from the piping.
3. Cap inlet piping after draining to keep water out of the pipes.
4. To prevent pump from freezing, remove trap cover and

drain the tank body through the two drain plugs provided.

- A. Gravity drain system as far as possible.
 - B. Protect areas which retain water with non-toxic propylene glycol antifreeze ("RV" antifreeze).
5. Clean pump thoroughly; replace trap cover.

NOTICE: Tighten trap cover by hand only (**no wrenches**)! If pump is not anchored, use caution to not break attached piping!

6. Be sure motor is kept dry and covered.

Startup For Winterized Equipment

1. Remove any temporary weather protection placed around system for shutdown.
2. Follow filter manufacturer's instructions for reactivation of the filter.
3. Inspect all electrical wiring for damage or deterioration over the shutdown period. Have a qualified serviceman repair wiring as needed.
4. Inspect and tighten all watertight connections.
5. Open all valves in suction and return piping.
6. Remove any winterizing plugs in piping system.
7. Drain all antifreeze from system.
8. Close all drain valves and replace all drain plugs in piping system.
9. Prime pump according to instructions on Page 9.

PUMP SERVICE

Pump should only be serviced by qualified personnel. For best results, use only genuine Sta-Rite factory parts. Be sure to prime pump (Page 9) before starting.

⚠ CAUTION Before removing trap cover:

1. **STOP PUMP** before proceeding.
2. **CLOSE GATE VALVES** in suction and discharge pipes.
3. **RELEASE ALL PRESSURE** from pump and piping system.

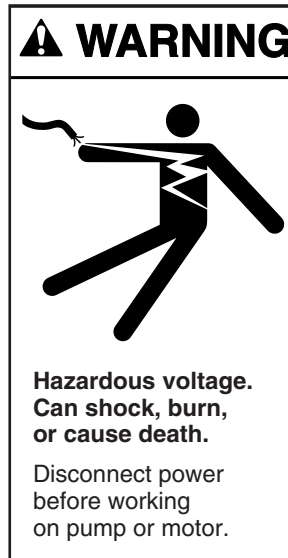

⚠ To avoid dangerous or fatal electrical shock hazard, turn OFF power to motor before working on pump or motor.

Aside from lubricating trap cover O-Ring, no lubrication or regular maintenance is needed beyond reasonable care and periodic cleaning of strainer basket.

If shaft seal is worn or damaged, repair as follows:

Pump Dissassembly/Removing Old Seal

Disconnect power to pump motor.

⚠ Be sure valves on suction and return piping are closed before starting work.

Release all pressure by opening all vents before starting work.

1. Drain pump by removing drain plugs on bottom of pump body and trap body.
2. **Be sure** there is no pressure in trap body; remove cover (unscrew by turning counterclockwise).
3. Remove 6 nuts, lockwashers and flat washers holding seal plate to pump body. Pull seal plate and motor away from pump body. (You may have to CAREFULLY use a screwdriver to separate body from seal plate.)
4. Remove seven screws and washers holding diffuser to seal plate. Remove diffuser.
5. Remove motor canopy. Being careful not to touch capacitor terminals, loosen capacitor clamp and move capacitor to one side.
6. Hold shaft with 7/16" open-end wrench on motor shaft flats.
7. Unscrew impeller from shaft (turn counterclockwise when facing it).
NOTICE: On 2 HP model, remove impeller screw (left hand thread - turn **clockwise**) and gasket before removing impeller. Inspect gasket for damage, cracks, etc. Replace if damaged.
8. Remove four screws holding seal plate to motor.
9. Place seal plate face down on flat surface and tap out ceramic seat (Figure 6).
10. Remove slinger from motor shaft and inspect for damage or abrasion.
11. Clean seal cavity in seal plate and clean motor shaft.

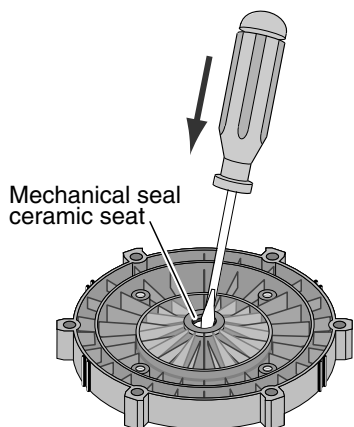

Figure 6

Pump Reassembly/Installing New Seal

1. Ceramic seat must be clean and free of dirt, grease, dust, etc. Wet outer edge with small amount of liquid detergent; press ceramic seat into seal plate cavity firmly and squarely with finger pressure (Figure 7).

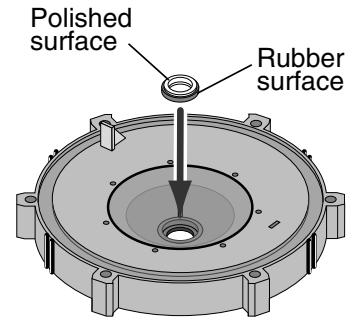

Figure 7

2. If ceramic seat will not locate properly, remove it, place **face up** on bench and reclean cavity. Ceramic seat should now locate.
3. If seat still will not locate properly, place a cardboard washer over the polished face and use a piece of 3/4" (19mm) standard pipe for pressing purposes.
NOTICE: **Be sure** not to scratch or mar polished surface or seal will leak.
4. Replace slinger on end of motor shaft so that impeller sleeve will push it into position. If slinger shows signs of wear or damage, replace it.
5. Remount seal plate on motor. Tighten bolts to 60-80 inch-lbs. (69-92 kg/cm) torque.
6. Apply a **small** amount of liquid detergent to inside diameter of rotating half of seal.
7. Slide rotating seal member, polished carbon face out, over impeller sleeve until rubber drive ring hits back of impeller.
NOTICE: **Be sure** not to nick or scratch polished seal face; seal will leak if face is damaged.
8. Screw impeller onto shaft (clockwise); this will automatically locate seal in seal plate.
NOTICE: On 2 and 2-1/2 HP models; install impeller gasket and lock screw (left-hand thread - turn **counterclockwise**). Torque lock screw to 50-55 inch-lbs. (57.6-63 kg/cm).
9. Mount diffuser on seal plate; tighten screws to 10-14 inch-lbs. (11.2-16.1 kg/cm) torque.
10. Assemble motor and seal plate to pump body with nuts, flat washers and lock washers. Torque nuts to 120-130 in-lbs. (138-150 kg/cm).
11. Prime pump according to instructions on Page 9.

TROUBLESHOOTING GUIDE

⚠ Read and understand safety and operating instructions in this manual before doing any work on pump!

⚠ Only qualified personnel should electrically test pump motor!

FAILURE TO PUMP; REDUCED CAPACITY OR DISCHARGE PRESSURE

Suction leaks/lost prime:

1. Pump must be primed; make sure that pump volute and trap are full of water. See priming instructions, Page 9.
2. Make sure there are no leaks in suction piping.
3. Make sure suction pipe inlet is well below the water level to prevent pump from sucking air.
4. If suction trap O-Ring is defective, replace it.
5. Make sure pump is not trying to lift water more than 10' (3m).
6. Make sure suction pipe is at least 2" (51mm) in diameter.

Clogged pipe/trap/impeller, worn impeller:

7. Make sure suction trap is not clogged; if it is, clean trap and strainer.
8. Make sure impeller is not clogged (follow steps 1 through 7 under "Removing Old Seal", Page 11; check impeller for clogging; follow steps 7 through 11 under "Installing New Seal", Page 11, for reassembly).
9. Impeller and diffuser may be worn. If so, order replacement parts from Repair Parts List, Pages 13 and 14.

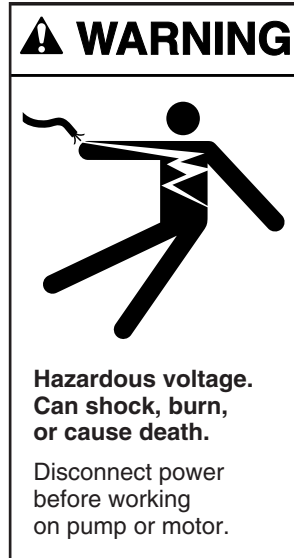

Electrical:

10. Pump may be running too slowly; check voltage at motor terminals and at meter while pump is running. If low, see wiring instructions or consult power company. Check for loose connections.
11. Pump may be too hot.
 - A. Check line voltage; if less than 90% or more than 110% of rated voltage consult a licensed electrician.
 - B. Increase ventilation.
 - C. Reduce ambient temperature.
 - D. Tighten any loose connections.

MECHANICAL TROUBLES AND NOISE

1. If suction and discharge piping are not adequately supported, pump assembly will be strained. See "Installation", Page 4.
2. Do not mount pump on a wooden platform! Securely mount on concrete platform for quietest performance.

REPAIR PARTS LIST DYNA-PRO™ POOL PUMP 1/2 through 2-1/2 HP Models Single Speed and Two Speed

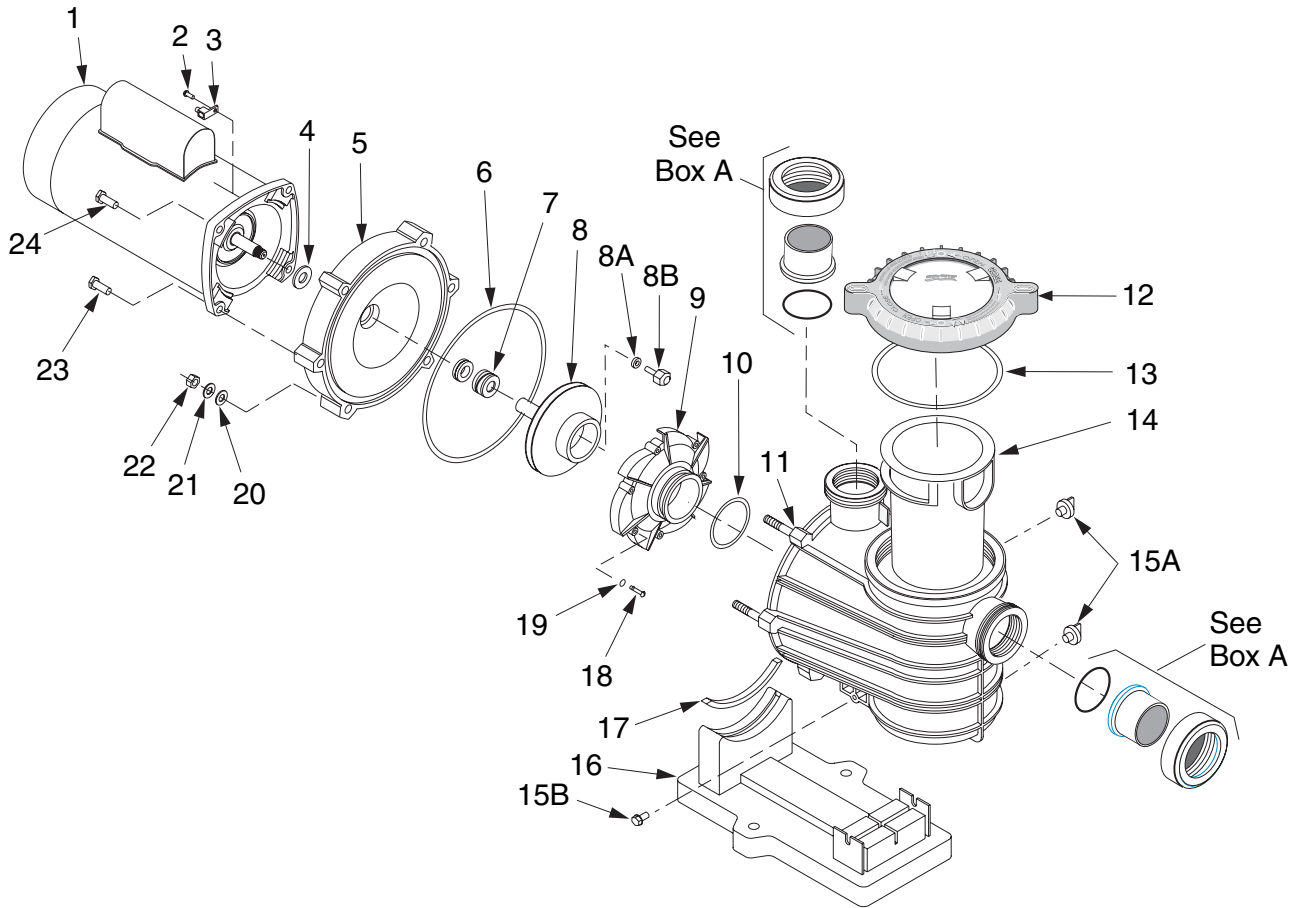

Model No.	HP	Motor (Key No. 1)
Single Speed 115/230/60/1		
MPRA6D-204L	3/4	A100DLL
MPRA6E-205L	1	A100ELL
MPRA6F-206L	1-1/2	A100FLL
MPEA6D-204L	3/4	AE100DLL
MPEA6E-205L	1	AE100ELL
MPEA6F-206L	1-1/2	AE100FLL
MPE6C-204L	1/2	AE100CHL
MPE6D-205L	3/4	AE100DHL
MPE6E-206L	1	AE100EHL
230/60/1		
MPRA6G-207L	2	A100GLL
MPEA6G-207L	2	AE100GLL
MPEAA6G-208L	2-1/2	AE100G5LL
MPE6F-207L	1-1/2	AE100FHL
MPE6G-208L	2	AE100G5HL
Two Speed 230/60/1		
MPRA6YF-206L	1-1/2	A100FLL-Y
MPEA6YG-207L	2	AE100GLL-Y
MPEAA6YG-208L	2-1/2	AE100G5LL-Y
MPE6YF-207L	1-1/2	AE100GLL-Y
MPE6YG-208L	2	AE100G5LL-Y

Box A

For quick disconnect pipe connections, purchase separately:
 Pkg. 188 2" Slip 1/2 Union Kit or
 Pkg. 189 2" NPT 1/2 Union Kit.

Includes:
 U11-200PS Union Collar
 U9-362 O-Ring
 U11-196P 2" Slip adapter or
 U11-199P 2" NPT adapter.

REPAIR PARTS LIST
DYNA-PRO™ POOL PUMP
1/2 through 2-1/2 HP Models Single Speed and Two Speed

Key No.	Part Description	Qty.	MPEA6D-204L MPE6C-204L MPRA6D-204L	MPEA6E-205L MPE6D-205L MPRA6E-205L	MPEA6F-206L MPE6E-206L MPRA6F-206L MPRA6YF-206L	MPEA6G-207L MPE6F-207L MPEA6YG-207L MPE6YF-207L MPRA6G-207	MPEAA6G-208L MPE6G-208L MPEAA6YG-208L MPE6G-208L
2	Screw #10-32x1/2"	1	U30-692SS	U30-692SS	U30-692SS	U30-692SS	U30-692SS
3	Bonding Lug	1	U17-568	U17-568	U17-568	U17-568	U17-568
4	Slinger	1	17351-0009	17351-0009	17351-0009	17351-0009	17351-0009
5	Seal Plate	1	C3-184P	C3-184P	C3-184P	C3-184P	C3-184P
6	Seal Plate Cord Ring	1	U9-373	U9-373	U9-373	U9-373	U9-373
7	Shaft Seal	1	37400-0027	37400-0027	37400-0027	37400-0027	37400-0027
8	Impeller	1	C105-236P	C105-236PB	C105-236PC	C105-236PDA	C105-236PEA
8A	Gasket	1	–	–	–	33455-1047	33455-1047
8B	Impeller Lock Screw	1	–	–	–	37337-6080	37337-6080
9	Diffuser	1	C1-270PB	C1-270PC	C1-270P	C1-270P	C1-270P
10	Diffuser O-Ring	1	U9-374	U9-374	U9-374	U9-374	U9-374
11	Tank and Trap Body (Only)	1	C76-71P	C76-71P	C76-71P	C76-71P	C76-71P
12	Trap Lid and Ring Assembly	1	17307-0111	17307-0111	17307-0111	17307-0111	17307-0111
13	Trap Cover O-Ring	1	35505-1440	35505-1440	35505-1440	35505-1440	35505-1440
14	Trap Basket	1	C8-58P	C8-58P	C8-58P	C8-58P	C8-58P
15A	Drain Plug	2	U178-920P	U178-920P	U178-920P	U178-920P	U178-920P
15B	Mounting Screw 5/16-14x5/8"	2	U30-919SS	U30-919SS	U30-919SS	U30-919SS	U30-919SS
16	Base - Plastic	1	C4-77P	C4-77P	C4-77P	C4-77P	C4-77P
17	Motor Pad - for Plastic Base	1	C35-45	C35-45	C35-45	C35-45	C35-45
18	Screw #8-32x7/8" Rd. Hd.	7	U30-542SS	U30-542SS	U30-542SS	U30-542SS	U30-542SS
19	Lock Washer #8 Ext. Tooth	7	U43-21SS	U43-21SS	U43-21SS	U43-21SS	U43-21SS
20	Flat Washer 3/8"	6	U43-62SS	U43-62SS	U43-62SS	U43-62SS	U43-62SS
21	Lock Washer 3/8"	6	U43-12SS	U43-12SS	U43-12SS	U43-12SS	U43-12SS
22	Nut 3/8-16 Hex	6	U36-38SSW	U36-38SSW	U36-38SSW	U36-38SSW	U36-38SSW
23	Cap Screws 3/8-16x1-1/4" Hex. (LS Suffix)	2	–	–	U30-75SS	U30-75SS	U30-75SS
24	Cap Screws 3/8-16x1" Hex.	4	U30-74SS	U30-74SS	U30-74SS	U30-74SS	U30-74SS
•	Nameplate	1	32155-4071	32155-4071	32155-4071	32155-4071	32155-4071
•	Tag, "CAUTION This pump equipped with mechanical shaft seal..."	1	61002-0012	61002-0012	61002-0012	61002-0012	61002-0012
•	Voltage Sticker	1	U27-153	U27-153	U27-153	U27-68	U27-68
•	Tag, "WARNING/CAUTION/Instructions..."	1	C63-12	C63-12	C63-12	C63-12	C63-12

• Not illustrated.

STA-RITE®