

HAYWARD® Pool Products

One source. Every pool.



**Models: HP20654T, HP20654BT, HP20854T,
HP20854BT and HP21104T**

OWNERS OPERATION & PARTS MANUAL

Attention
Installer:
Give this manual to
the homeowner.

Important Information to
keep for Service

Model # _____

Serial # _____

Install Date _____



R-410A



SAVE THIS OWNERS MANUAL

The Hayward HeatPro Heat Pump is listed by ETL as complying with the latest edition of the “UL Standard for Safety for Heating and Cooling Equipment”, UL1995 and CSA C22.2 No. 236.

All Hayward HeatPro Heat Pumps must be installed in accordance with all applicable National and Local codes. In the absence of local codes, refer to the latest edition of the National Electric Code (NEC) in the United States and the Canadian Electric Code (CEC) in Canada

Basic safety precautions should always be followed, including the following: Failure to follow instructions can cause severe injury and/or death.

⚠ This is the safety-alert symbol. When you see this symbol on your equipment or in this manual, look for one of the following signal words and be alert to the potential for personal injury.

⚠ WARNING warns about hazards that **could** cause serious personal injury, death or major property damage and if ignored presents a potential hazard.

⚠ CAUTION warns about hazards that **will** or **can** cause minor or moderate personal injury and/or property damage and if ignored presents a potential hazard. It can also make consumers aware of actions that are unpredictable and unsafe.

The **NOTICE** label indicates special instructions that are important but not related to hazards.

USE ONLY HAYWARD GENUINE REPLACEMENT PARTS

IMPORTANT SAFETY INSTRUCTIONS

READ AND FOLLOW ALL INSTRUCTIONS IN THIS OWNER'S MANUAL AND ON EQUIPMENT.



Before servicing this electrical equipment, turn power supply OFF.

KEEP ALL LABELS IN GOOD CONDITION AND REPLACE IF MISSING OR DAMAGED.

⚠ WARNING – To reduce risk of injury, do not permit children to use or climb on the heat pump, pumps or filters. Closely supervise children at all times. Components such as the filtration system, pumps, and heaters must be positioned to prevent children from using them as a means of access to the pool.

⚠ CAUTION – This heat pump is intended for use on permanently installed swimming pools and may also be used with spas. Do NOT use with storable pools. A permanently installed pool is constructed in or on the ground or in a building such that it cannot be readily disassembled for storage. A storable pool is constructed so that it is capable of being readily disassembled for storage and reassembled to its original integrity.

Though this product is designed for outdoor use, it is strongly recommended to protect the electrical components from the weather. Select a well-drained area, one that will not flood when it rains. It requires free circulation of air for cooling. Do not install in a damp or non-ventilated location.



⚠ WARNING – Risk of Electric Shock. All electrical wiring MUST be in conformance with all applicable local codes, regulations and the National Electric Code (NEC). Hazardous voltage can shock, burn, and cause death or serious property damage. Provide a properly located outlet. All electrical wiring MUST be in conformance with applicable local and national codes and regulations. Before working on this unit, turn off power supply to the heat pump.

⚠ WARNING – To reduce the risk of electric shock replace damaged wiring immediately. Locate conduit to prevent abuse from lawn mowers, hedge trimmers and other equipment.

⚠ WARNING – Failure to bond heat pump to pool structure will increase risk for electrocution and could result in injury or death. To reduce the risk of electric shock, the electrician must comply with installation instructions and must bond the heat pump accordingly. In addition, the licensed electrician must also conform to local electrical codes for bonding requirements.

Notes to the electrician:

Use a solid copper conductor, size 8 or larger. Run a continuous wire from external bonding lug to reinforcing rod or mesh. Connect a No. 8 AWG (8.4 mm²) solid copper bonding wire to the grounding lug provided on the heat pump and to all metal parts of swimming pool or spa, and to all electrical equipment, metal piping (except gas piping), and conduit within 5 ft. (1.5 m) of inside walls of swimming pool or spa. **IMPORTANT** - Reference NEC codes for all wiring standards including, but not limited to, grounding, bonding and other general wiring procedures.



⚠ WARNING – Suction Entrapment Hazard.

Suction in suction outlets and/or suction outlet covers which are damaged, broken, cracked, missing, or unsecured can cause severe injury and/or death due to the following entrapment hazards:

Hair Entrapment- Hair can become entangled in suction outlets.

Limb Entrapment- A limb inserted into an opening of a suction outlet or suction outlet cover that is damaged, broken, cracked, missing, or not securely attached can result in a mechanical bind or swelling of the limb.

Body Suction Entrapment- A differential pressure applied to a large portion of the body or limbs can result in an entrapment.

Evisceration/ Disembowelment - A vacuum applied directly to the intestines through an unprotected suction outlet sump or suction outlet cover which is damaged, broken, cracked, missing, or unsecured can result in evisceration (disembowelment).

Mechanical Entrapment- There is potential for jewelry, swimsuit, hair decorations, finger, toe or knuckle to be caught in an opening of a suction outlet or suction outlet cover resulting in mechanical entrapment.

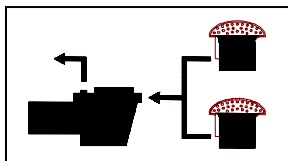

⚠ WARNING - To reduce the risk of entrapment hazards:

- o When suction outlets are less than a 18" x 23" [45cm x 58cm] equivalent, a minimum of two functioning suction outlets per pump must be installed. Suction outlets in the same plane (i.e. floor or wall), must be installed a minimum of three feet (3') [1 m] apart, as measured from near point to near point.
- o Dual suction outlets shall be placed in such locations and distances to avoid "dual blockage" by a user.

USE ONLY HAYWARD GENUINE REPLACEMENT PARTS

- Dual suction fittings shall not be located on seating areas or on the backrest for such seating areas.
- The maximum system flow rate shall not exceed the flow rating of any listed (per current revision of ASME/ANSI A112.19.8) suction outlet cover installed.
- Never use the Pool or Spa if any suction outlet component is damaged, broken, cracked, missing, or not securely attached.
- Replace damaged, broken, cracked, missing, or not securely attached suction outlet components immediately.
- In addition two or more suction outlets per pump installed in accordance with latest APSP (formerly NSPI) Standards and CPSC guidelines, follow all National, State, and Local codes applicable.

▲ WARNING – Never operate or test the circulation system at more than 50 PSI.

▲ WARNING – Failure to remove pressure test plugs and/or plugs used in winterization of the pool/spa from the suction outlets can result in an increase potential for suction entrapment as described above.

▲ WARNING – Failure to keep suction outlet components clear of debris, such as leaves, dirt, hair, paper and other materials can result in an increase potential for suction entrapment as described above.

▲ WARNING – Suction outlet components have a finite life, the cover/grate should be inspected frequently and replaced at least every ten years or if found to be damaged, broken, cracked, missing, or not securely attached.

▲ WARNING – All suction and discharge valves MUST be OPEN when starting the circulation system. Failure to do so could result in severe personal injury and/or property damage. All drains and suction outlets MUST have properly installed covers, securely attached using the screws supplied with the covers. If screws are lost, order replacement parts from your supplier.



▲ WARNING – Hazardous Pressure. Pool and spa water circulation systems operate under hazardous pressure during start up, normal operation, and after pump shut off. Stand clear of circulation system equipment during start up. Failure to follow safety and operation instructions could result in violent separation of the pump housing and cover due to pressure in the system, which could cause property damage, severe personal injury, or death. Before servicing pool and spa water circulation system, all system and pump controls must be in off position and filter manual air relief valve must be in open position. Before starting system pump, all system valves must be set in a position to allow system water to return back to the pool. Do not change filter control valve position while system pump is running. Before starting system pump, fully open filter manual air relief valve. Do not close filter manual air relief valve until a steady stream of water (not air or air and water) is discharged.



▲ WARNING – Separation Hazard. Failure to follow safety and operation instructions could result in violent separation of pump components. Strainer cover must be properly secured to pump housing with strainer cover lock ring. Before servicing pool and spa circulation system, filter manual air relief valve must be in open position. Do not operate pool and spa circulation system if a system component is not assembled properly, damaged, or missing. Do not operate pool and spa circulation system unless filter air relief valve body is in locked position in filter upper body.

▲ WARNING – **Fire and burn hazard.** Motors operate at high temperatures and if they are not properly isolated from any flammable structures or foreign debris they can cause fires, which may cause severe personal injury or death. It is also necessary to allow the motor to cool for at least 20 minutes prior to maintenance to minimize the risk of burns.

▲ WARNING – Failure to install according to defined instructions may result in severe personal injury or death.

▲ WARNING – The following “Safety Rules for Hot Tubs” recommended by the U.S. Consumer Product Safety Commission should be observed when using the spa.

1. Spa or hot tub water temperatures should never exceed 104°F [40°C]. A temperature of 100°F [38°C] is considered safe for a healthy adult. Special caution is suggested for young children. Prolonged immersion in hot water can induce hyperthermia.
2. Drinking of alcoholic beverages before or during spa or hot tub use can cause drowsiness, which could lead to unconsciousness and subsequently result in drowning.
3. **Pregnant women beware!** Soaking in water above 100°F. [38°C] can cause fetal damage during the first three months of pregnancy (resulting in the birth of a brain-damaged or deformed child). Pregnant women should adhere to the 100°F. [38°C] maximum rule.
4. Before entering the spa or hot tub, users should check the water temperature with an accurate thermometer; spa or hot tub thermostats may err in regulating water temperatures by as much as 4°F (2.2°C).
5. Persons taking medications, which induce drowsiness, such as tranquilizers, antihistamines or anticoagulants, should not use spas or hot tubs.

USE ONLY HAYWARD GENUINE REPLACEMENT PARTS

6. If the pool/spa is used for therapy, it should be done with the advice of a physician. Always stir pool/spa water before entering the pool/spa to mix in any hot surface layer of water that might exceed healthful temperature limits and cause injury. Do not tamper with controls, because scalding can result if safety controls are not in proper working order.
7. Persons with a medical history of heart disease, circulatory problems, diabetes or blood pressure problems should obtain a physicians advice before using spas or hot tubs.
8. Hyperthermia occurs when the internal temperature of the body reaches a level several degrees above normal body temperature of 98.6°F. [37°C]. The symptoms of Hyperthermia include: drowsiness, lethargy, dizziness, fainting, and an increase in the internal temperature of the body.

The effects of Hyperthermia include:

1. Unawareness of impending danger.
2. Failure to perceive heat.
3. Failure to recognize the need to leave the spa.
4. Physical inability to exit the spa.
5. Fetal damage in pregnant women.
6. Unconsciousness resulting in danger of drowning.

DEFINITIONS:

Suction Outlet – The term Suction Outlet is a fitting, fitting assembly, cover/grate and related components that provide a means for water to exit the pool and into the pump circulating system.

Inches of Mercury (in Hg) - A unit for measuring pressure below atmospheric (“suction” or “vacuum”) (1.0 inch Hg = .491 PSI)

Main Drain – See Suction Outlet

PSI – An abbreviation for pounds per square inch.

General Information:

Swimming Pool Energy Saving Tips

It is important to note that a heat pump will not heat a pool as fast as a gas heater. If the pool water is allowed to cool significantly, it may take a heat pump several days to return pool water to the desired temperature. For weekend use, it is more economical to maintain the pool water temperature at the desired temperature.

Hayward Pool Products offers the following recommendations to help conserve energy and minimize the cost of operating the heat pump.

1. Carefully monitor the water temperature of the pool in the summertime.
2. During the winter or when on vacation longer than a week, turn off the heat pump and follow the winterization procedures in this manual. If pool use is not planned for a prolonged period, energy consumption can be minimized by either turning off the heat pump or by decreasing the temperature setting several degrees.
3. Where possible, shelter the pool from prevailing winds with well-trimmed hedges or other landscaping, cabanas, or fencing.
4. The use of a pool cover is recommended. A pool cover will provide a valuable safety feature, reduce heat loss, conserve chemicals, and reduce the load on filter systems.

USE ONLY HAYWARD GENUINE REPLACEMENT PARTS

The following table lists the minutes it will take to heat a pool 1°F, based on gallons. This is an approximation only.

Model	HP20654T & HP20654BT				HP20854T & HP20854BT				HP21104T			
Pool Size in Gallons	80°F	70°F	60°F	50°F	80°F	70°F	60°F	50°F	80°F	70°F	60°F	50°F
200	3	3	3	3	2	2	2	2	1	1	2	2
500	5	7	7	9	4	5	5	6	3	3	3	4
1000	11	14	16	17	8	10	11	12	5	6	6	7
1500					13	14	16	18	8	9	9	11
2000					17	19	21	24	10	12	12	14
5000									25	29	31	35
10000									50	58	62	71
20000									100	116	125	141

Features:

- UV resistant cabinet;
- Scroll compressor for quiet operation;
- Energy efficient heating of your pool and spa;
- Digital Electronic Control (All Models):
 - o Easy to read display;
 - o Continuous digital temperature display;
 - o Dual thermostats for independent temperature control of pool and spa
 - o Display of self diagnostic codes to monitor heat pump performance;
 - o Control Lock Out Function;
 - o Defrost Function to prevent evaporator coil freeze up;
- Titanium Heat Exchanger withstands the harshest conditions.

USE ONLY HAYWARD GENUINE REPLACEMENT PARTS

How a Heat Pump Works

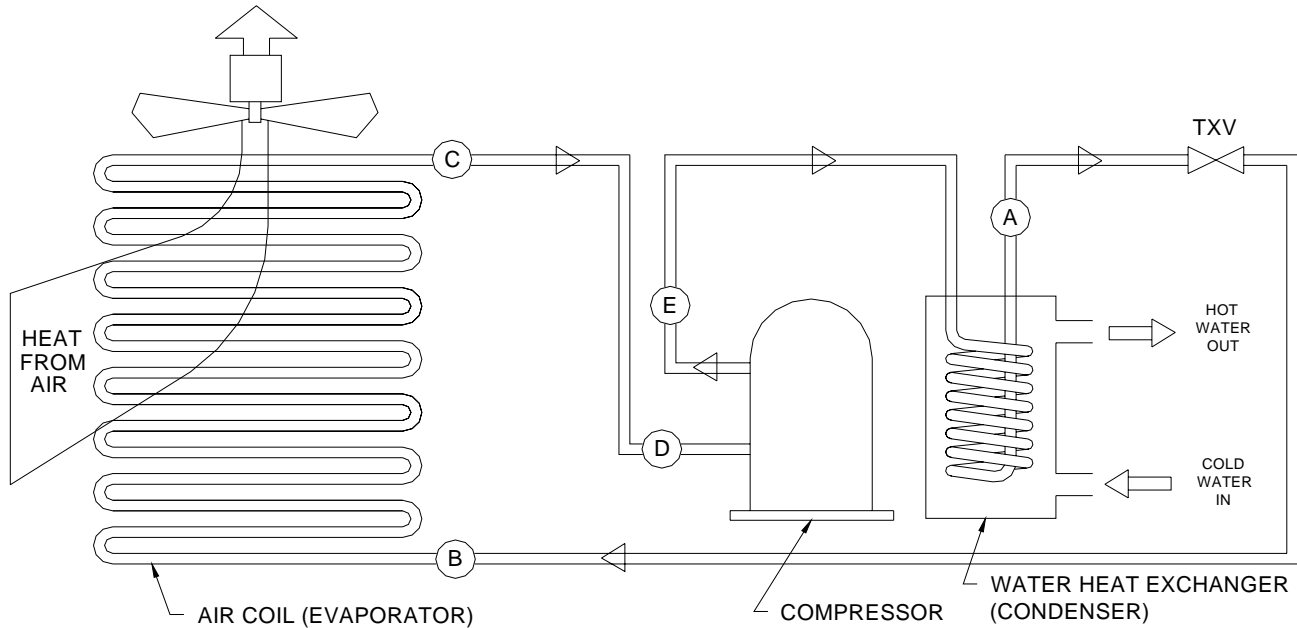

The heat pump takes heat from the environment and uses it to heat the pool water. During heat pump operation, high temperature, high-pressure sub cooled liquid Refrigerant (A) is throttled by Metering Device (TXV) and turned into low temperature, low-pressure saturated liquid (B). The two-phase Refrigerant flows through the Air Coil (Evaporator), where the liquid refrigerant evaporates into vapor by absorbing heat from the surrounding air. At the outlet of the Air Coil (Evaporator) it becomes a low temperature, low-pressure superheated vapor (C). The Compressor receives this flow at the suction line (D), and compresses it into a high temperature, high pressure superheated vapor, which is discharged from the Compressor (E) and flows into the Water Heat Exchanger (Condenser). The heat carried by the flow is then released to the surrounding water from the pool. At the same time, the high temperature, high-pressure superheated vapor is then condensed back to high-pressure sub cooled liquid (A), which completes the cycle. The water, which is being forced through the Water Heat Exchanger (Condenser) by the pool pump, is heated as it passes through.

Becoming Familiar with Your Heat Pump

Heat Pump Protection Features

Hayward heat pumps are equipped with safeguards that will stop operation to protect the unit in case of the following events:

- Excessively high refrigerant pressure
- Excessively high water temperature
- Loss of refrigerant
- Fan Motor Failure
- Evaporator Freeze-up
- Low Ambient Temperature

USE ONLY HAYWARD GENUINE REPLACEMENT PARTS

High / Low Refrigerant Pressure Switches

- The high-pressure switch senses the refrigerant pressure in the sealed refrigeration system and turns the heat pump off if the operating pressure exceeds the acceptable range. The heat pump will automatically reset the switch after the system pressure returns to normal operating conditions. The display will show “HI”, if this switch is tripped.
- The low-pressure switch senses the refrigerant pressure in the sealed refrigeration system to protect against certain conditions that could be detrimental to compressor life. The switch turns the heat pump off in the event of loss of refrigerant, fan motor failure, evaporator freeze-up, or airflow blockage. The heat pump will automatically reset the switch after the system pressure returns to normal operating conditions. The display will show “LP”, if this switch is tripped.

Water Pressure Switch

Adequate water flow through the heat pump causes the Water Pressure Switch contacts to close. Insufficient water pressure will allow these contacts to open, and turn the heat pump off. The display will read “PS” if the water pressure is not sufficient.

Time Delay

All models use a 5-minute time delay. Any interruptions, outside of power loss, will result in a 5-minute time delay.

Low Ambient Temperature

If the air outside the heat pump is too cold, the heat pump will not operate. The actual point at which the unit will cease operating due to low temperature varies. Current weather conditions, the amount of sunlight reaching the heat pump, and the installation quality are primary contributors to this event. The shutdown will occur near 50°F (10°C). This is not a “fixed” range. Low outside air temperatures will activate the systems defrost function by lowering the evaporator’s outlet temperature. The fan motor will operate independently for 15 minutes in attempts to raise the evaporator coil temperature, at which time the heat pump’s control system will check the temperature to see if the coil has warmed up sufficiently to return to normal operation. The control system will run through three 15 minute cycles checking the coil temperature. In the event that the coil does not return to normal operating temperature following the three 15 minute cycles, the heat pump’s control system will shut the unit down completely for 2 hours (display will show “dEF”). After the 2-hour period, the unit will restart to check the evaporator temperature and try to resume normal operation. The heat pump control will continue this cycle until the evaporator temperature returns to normal.

USE ONLY HAYWARD GENUINE REPLACEMENT PARTS

Clearance

A minimum of 2 feet (.6 m) of clearance from walls, shrubbery, equipment, etc. is required around the entire heat pump. This allows for ample air intake. A minimum of 6 feet (2 m) of clearance above the heat pump is required to prevent re-circulation of air. The unit should not be placed underneath eaves, decks, or porches, as this causes re-circulation of air.

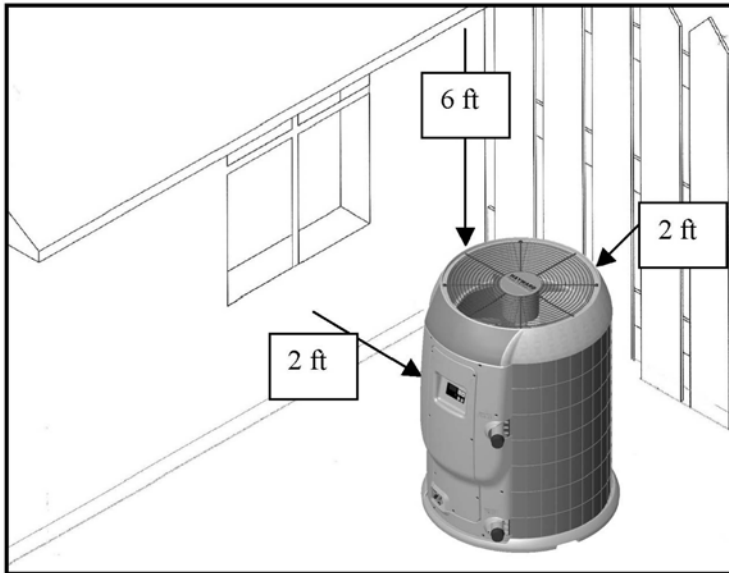

RE-CIRCULATION OF AIR BACK INTO THE PUMP WILL GREATLY REDUCE ITS EFFICIENCY

Roof Run-Off

NOTICE - Make sure the heat pump is not located where water may run-off from the roof into the unit. Sharp sloping roofs without gutters will allow large amounts of rainwater, mixed with debris from the roof to be forced through the unit. This will clog, damage, and corrode the unit.

NOTE: A gutter or down spout may need to be installed to protect the heat pump.

Drainage and Condensation

THE HEAT PUMP GENERATES WATER CONDENSATION DURING NORMAL OPERATION. THIS SHOULD NOT BE MISTAKEN FOR A LEAK IN THE UNIT.

A drain hole is provided in the in base pan for adequate removal of condensation and rainwater. Condensation will be produced by the evaporator coil while the unit is running and drain at a steady rate, usually **3 to 5 gallons per hour**, depending upon ambient air temperature and humidity. The more humid the ambient air, the more condensation will be produced. If drainage is above this range during operation or if water continues to drain from the base when the heat pump is not in operation for more than an hour, a leak in the internal plumbing may have occurred. The troubleshooting section provides recommendations if leaks are suspected.

NOTICE: Keep the drain hole clear of debris and clean it regularly to remove any obstruction.

USE ONLY HAYWARD GENUINE REPLACEMENT PARTS

NOTICE

Make sure there are no sprinkler heads near the heat pump that will spray on or into the unit. **Sprinkler damage is not covered under the warranty agreement.**
Make sure that sprinklers are placed at a sufficient distance away, so that normal wind will not carry the mist to the heat pump.

The heat pump is designed to handle the wettest weather conditions that are typical of rain and high humidity. Sprinkler heads force high-pressure water into the unit from the side at odd angles. Many sprinkler systems are connected to a ground well system, whose water is high in minerals, sulphur, and other aggressive contaminants that will leave a build up on the evaporator coils causing corrosion and hampering efficiency. If the installed location is within 15 miles of the coast, salt may also be in the well water. Salt contaminated ground well water increases the rate of corrosion and greater care needs to be taken to direct sprinkler water away from the heat pump.

NOTICE- If in an oceanfront area, the heat pump should be placed out of direct spray of sand and salt. This will clog, damage, and corrode the unit, which will void the warranty. You may also consider protecting the unit by planting shrubbery or installing a privacy fence between the unit and the prevailing beachfront wind.

NOTICE – Damage caused by sand or salt spray will void the warranty.

POOL COVERS ARE STRONGLY RECOMMENDED**Using a Pool Cover**

A pool loses heat in several ways and testing shows that evaporative cooling (the cooling effect created by water evaporating from the surface of the pool) accounts for approximately 75% of a pool's heat loss. However, if a pool is covered when not in use, most evaporative cooling can be prevented. If the pool temperature is to be maintained, the pool heating system must replace the heat lost; therefore the use of a pool cover can offer dramatic savings in energy consumption.

A pool cover that reduces evaporative cooling can reduce the heat lost from a pool by approximately 50% (which also reduces your power consumption by 50%).

USE ONLY HAYWARD GENUINE REPLACEMENT PARTS

Operating the HeatPro Heat Pump

NOTICE- Do not use this heat pump if any part has been flooded or submerged in water. Immediately call a qualified technician to inspect and replace any damaged part of the heat pump. Control System components must be replaced if submerged in water. Failure to do so will cause property damage.

Before proceeding, **MAKE CERTAIN** there are no air or water leaks in any plumbing connections or piping and water is flowing through the unit as setup by the installer.

NOTE: Damage caused by flow rates outside this range will void the warranty.

▲ CAUTION - Keep all objects off the top of the heat pump. Blocking airflow could damage the unit and will void the warranty.

Start-Up Procedures

1. Apply power to the pool heater by plugging in the non-fused disconnect block or moving the circuit breaker to the “ON” position.
2. Place the pool heater thermostat in the “Standby” mode by ensuring the light above the “POOL” button (and “SPA” button for dual thermostat application) is not illuminated. If the light(s) are lit, depress the “POOL” button (and “SPA” button for dual thermostat application) to put the unit in “STANDBY” mode.
3. With the pool filter pump operating properly.
4. Push the “POOL” button to activate the unit and then set the pool Heat Pump thermostat to a temperature higher than the current pool water temperature.
5. Allow 5 Minutes for the Heat Pump to start.
6. When the unit starts, confirm that air is being discharged upward from the unit and the air is cooler than the ambient air.
7. Allow the Heat Pump to operate for 10-15 minutes in order for system pressure to stabilize.
8. If Heat Pump fails to start:
 - a) Check water flow
 - b) Ensure that power is On
 - c) Refer to Performance Monitoring Section of this Manual

USE ONLY HAYWARD GENUINE REPLACEMENT PARTS

Becoming Familiar with HeatPro Heat Pump Controls

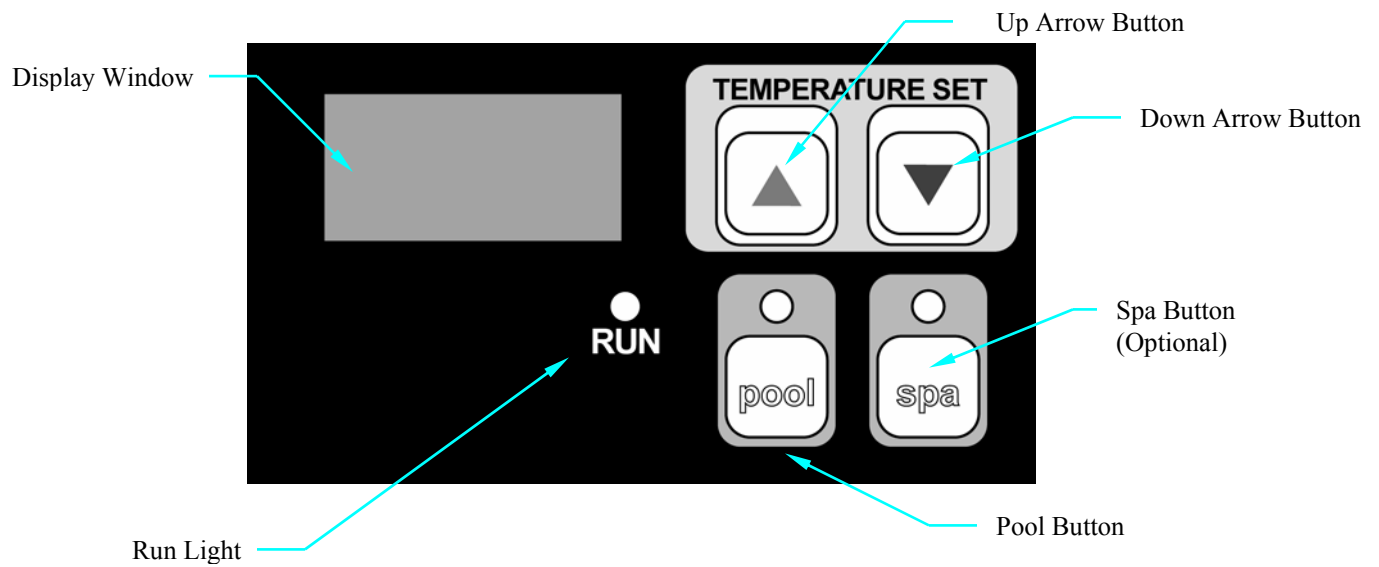

Heat Pump Control Panel

Display Window (All Models)

When power is supplied to the unit, the display will either show temperature (in degrees F or C), diagnostic code (such as “rhd”), or scrolling dots.

Up Arrow Button (All Models)

Raises the heat pump temperature set point.

Down Arrow Button (All Models)

Lowers the heat pump temperature set point.

Pool Button (All Models)

Activates the pool function of the controller.

Spa Button (All Models)

Activates the spa function of the controller.

Run Light (All Models)

Indicates the unit is operating normally and the thermostat is making a demand for heat.

USE ONLY HAYWARD GENUINE REPLACEMENT PARTS

Control Operation

Dual Thermostat (Models HP20654T, HP20654BT, HP20854T, HP20854BT & HP21104T)

- On/Off:** This control does not have a true on/off feature. The unit uses *standby* mode instead. Scrolling dots in the display indicate standby. *Standby* mode serves two functions. (1) It serves as an “off” mode, which keeps the heat pump from transferring heat into your pool water. (2) *Standby* allows a pool owner with remote controlling systems, such as Goldline, to maintain pool and spa temperatures via the remote.
- To enter *Standby* mode: If *pool* mode is active (indicated by the green led over the *pool* button), press the *pool* button once. Rolling dots should appear on the display. If *spa* mode is active (indicated by the green led over the *spa* button), press the *spa* button once. Rolling dots should appear on the display.
- To exit *Standby* mode: Press either the *pool* or *spa* mode button.
- Mode Selection:** Select the desired mode of operation (*spa* or *pool*) by using the POOL / SPA buttons. A green LED above the buttons designates the active mode. When the *pool* mode is active, any displays or adjustments apply only to the *pool* mode. Adjustments for *spa* mode must be made while the *spa* button is activated. A user can switch between modes without turning the control to *standby* first.
- Run Indicator Light:** Shows the unit is operating normally and the thermostat is making a demand for heat.
- Temperature Set point:** *Pool* and *spa* mode range is 50-104°F (21-40°C).
- Adjust the set point:* Continuing to hold the *up* or *down arrow* button will adjust the set point value until the desired set point is reached. When the desired value has been reached, release the button. The new set point will flash to indicate a new value has been recognized and the display will revert back to water temperature as indicated by a steady display.
- To display the set point:* Press and release the *up* or *down arrow* button once to display the current set point for 3 seconds. For help with this type of control, refer to Troubleshooting Guide with Digital Control.

USE ONLY HAYWARD GENUINE REPLACEMENT PARTS

Changing Temperature Display (All Models):

The control will display temperatures in either degrees Fahrenheit or Celsius. To change the temperature display, place the heat pump in “Stand-By” mode so that the scrolling dots appear on the screen. Press and hold both the *pool* button and the *down arrow* button for two seconds and release. Place the heat pump back in *pool* or *spa* mode and the temperature change will be displayed. When viewing the temperature in degrees Fahrenheit only the numeric temperature is displayed, but when viewing degrees Celsius the control will display the numeric temperature followed by a lower case “c”.

Lock Out Feature (All Models):

A lock out function is provided to keep the temperature set point from being changed. To engage this function in the *pool* or *spa* mode press the *up arrow button*, *down arrow button* and *pool button* at the same time and hold for 2 seconds. The control display will read “LOC” while the lock out function is engaged. To exit the lock out function in *pool* or *spa* mode press the *up arrow button*, *down arrow button* and *pool button* at the same time.

Defrost Function (All Models):

The Defrost function is provided to prevent the evaporator coil from freezing when the outside air temperature is near 50°F (10°C). There is no exact temperature at which this function will operate, as each unit will vary depending upon conditions surrounding the heat pump, clearance around the heat pump and heat pump maintenance. This time period will vary from 15 minutes to several hours.

Maintenance

Water Chemistry

Proper chemical balances are necessary for sanitary swimming conditions as well as ensuring your heat pump’s long term reliability.

Sanitizing Equipment

Sanitizers, if used, **MUST** be installed downstream of the heat pump (in the return line to the pool) and a check valve installed in a manner that will not allow the raw chlorine to drain back to the heat pump when the water filter pump is off. This will prolong the overall life of the heat pump. **DO NOT POUR CHEMICALS DIRECTLY INTO THE SKIMMER.**

Inspection and Service

Hayward HeatPro heat pumps are designed and constructed to provide long performance life when installed and operated properly under normal conditions. Periodic inspections are important to keep your heat pump running safely and efficiently through the years.

Keep all objects off the top of the heat pump. Blocking airflow could damage the unit and void the warranty.

USE ONLY HAYWARD GENUINE REPLACEMENT PARTS

Owner Inspection

Hayward recommends that you inspect your heat pump on a seasonal basis and especially after significant weather events. Refer to the sections of this Manual: “Clearance”, “Roof Run-Off”, “Drainage and Condensation” for proper inspection.

Professional Inspection

⚠ WARNING - RISK OF ELECTRIC SHOCK OR ELECTROCUTION. Before servicing heat pump or motor, disconnect ALL electrical power. An EPA Certified service technician **MUST** perform inspection.

Note: Hayward recommends annual equipment inspections.

Note: Never use high-pressure water to clean evaporator coil fins, as this will cause damage to the coil.

Summertime Shutdown

For certain areas during the summer months, when the heat pump is not needed, you can place the heat pump in standby mode.

End of Season (Winterizing)

Failure to properly winterize heat pump may result in serious equipment damage. **Freeze damage is NOT covered under the heat pump warranty.**

Many pool service companies offer “Winterizing” assistance. Hayward recommends using a professional service technician for these procedures.

- All cleaning of the heat pump. Incorrect cleaning of the unit can cause damage to the heat pump and diminish the operating life.
- Disconnect the power supply (usually at the circuit breaker in your house) prior to winterizing your heat pump.

Cover the heat pump to protect it from snow and water, which may freeze and damage the unit. **BE ABSOLUTELY CERTAIN TO DISCONNECT THE HEAT PUMP FROM THE UNIONS AND DRAIN ALL WATER LINES.**

USE ONLY HAYWARD GENUINE REPLACEMENT PARTS

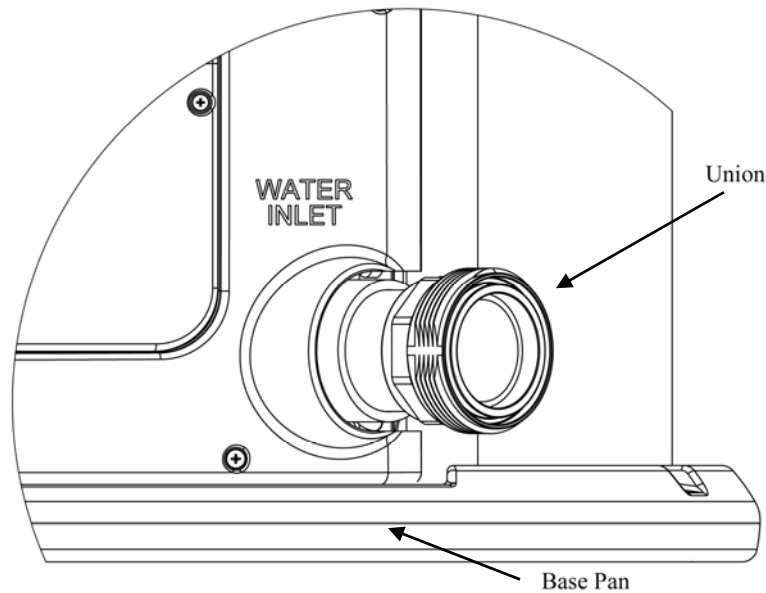

Some heat pump owners desire their pool to be heated during the winter months. This is possible when daytime temperatures are above 50°F [10°C] for most of Hayward's heat pumps. If temperatures fall below freezing, be certain to keep the pool filter pump operating continuously to prevent freeze damage.

⚠ WARNING - While the plumbing connections are in the winterized condition (disconnected from heat pump), it is imperative that the pool / spa water is NOT circulated through the heat pump. Loss of water through loose plumbing connections may result in damage to circulating pump, pool / spa structure and / or other equipment.

Performance Maintenance and Troubleshooting

Service Procedures

Before Calling For Service

If there appears to be a problem, refer to the troubleshooting section on the following pages.

1. Ensure the swimming pool filtration system is turned on.
2. Ensure the main power circuit on.
3. Verify that the heat pump is not in stand-by mode (pool or spa indicator light is illuminated).
4. Ensure that the heat pump thermostat is set at a temperature above that of the pool or spa temperature.
5. Ensure the outside temperature is high enough to allow the unit to operate. Hayward heat pumps will not turn on when the outside air temperatures near 50°F (10°C).

USE ONLY HAYWARD GENUINE REPLACEMENT PARTS

6. Ensure that the pump and skimmer baskets are clean; also ensure that the pool filter is clean and supplying proper water flow to the heat pump.
7. If the heat pump is not able to maintain the desired temperature, depending on the time of the year, it may be necessary to adjust your pool filtration systems hours of operation (increase run time).
8. If the heat pump does not appear to be heating, check the air temperature being blown out of the top. If the air coming out is cooler than the ambient air, the unit is functioning. If the two temperatures are the same, there may be a problem.

Note: Use a solar blanket / cover on the surface of the pool in order to minimize heat loss.

USE ONLY HAYWARD GENUINE REPLACEMENT PARTS

Troubleshooting

Circuit Breakers: If it is suspected that a circuit breaker is tripped, turn the breaker to the “Off” position and then back to the “On” position.

NOTICE: Service to be conducted **ONLY** by an EPA Certified Service Technician.

General Troubleshooting Guide for Hayward HeatPro Heat Pump			
Problem	Possible Cause	Possible Solution(s)	
Unit is not operating.	No power to unit	Make sure power is on.	
	Breaker is tripped	Check the breaker / see note above	
	Thermostat not turned up high enough	Turn thermostat up until unit comes on	
	5 minute delay timer still running	Be sure the 5 minute delay has passed	
	Low water flow	Make sure filter, strainer basket and skimmer basket are clean	
		Make sure filter pump is on	
		Unhook cleaning devices (skimmers, crawlers, etc.)	
Outside temperature too low	Check outside ambient temperature or wait for warmer temperatures to operate. (refer to Operating section)		
Fan not functioning	Call Pool Service Provider.		
Heat pump is running but is not heating “Run” light does not come on.	Check output air temperature to input air temperature. Differential should be between 5 and 12 °F	Low ambient air temperature. Allow outside air temperature to exceed 60°F, and then re-check.	
	System Component failure.	Call Pool Service Provider.	
Heat pump runs continually	Thermostat set too high	Turn thermostat down	
	Electrical component failure	Turn off the filter pump. If the unit is still running after 2 minutes, turn off the power to the unit and call Pool Service Provider.	
Heat pump is cycling (on / off too quickly)	Bad valve or improper water flow	Check valve settings and ensure water flow is sufficient (is the filter pump running continually?) If heat pump continues to cycle, turn unit off to prevent compressor damage.	
	Low refrigerant, low ambient temp, or high humidity with low ambient temp	Check evaporator coil for severe frost. Turn unit off to prevent compressor damage. Allow the evaporator to thaw and restart. If issue continues, call a pool service provider.	
		If heat pump continues to cycle, turn unit off to prevent compressor damage- and call Pool Service Provider.	
Water is coming from bottom of unit	Condensation	This is normal and there is no reason to be concerned	
	Possible water leak	Turn the unit off for several hours, but leave the filter pump running continuously. If water discharge ceases, then it is only condensation. Otherwise there is a possible leak.	

USE ONLY HAYWARD GENUINE REPLACEMENT PARTS

Display Diagnostic Codes - Troubleshooting Guide for Hayward HeatPro Heat Pump			
Display	Problem	Possible Cause	Solution
(Blank)	No power to heat pump	Tripped circuit breaker/ no power supply	Check breaker and ensure that the unit is properly installed.
	Unit will not turn on	Faulty electrical component	Call Pool Service Provider.
		5-minute delay	Wait 5 minutes
PS	Water Pressure Switch	Low or no water flow	Check water flow to heat pump
			Clean the filter
			Make sure all valves are open and bypass valve is closed
			Ensure pool filter pump is on
			Normal operation for TCO function
			Turn off fountains, etc.
LP	Low Pressure Switch	Air flow obstruction	Perform/verify maintenance as described in this manual.
			Call Pool Service Provider.
HI	High Pressure Switch	Low water flow	Check water flow to heat pump. .
			Clean the filter, strainer basket and skimmer basket
			Make sure all valves are open and bypass is closed.
		High water temp	Ensure pool filter pump is on and turn off fountains.
			Set unit to "ACP" if the unit has the heat / cool option. Refer to text on HP3100 control board.
			Check pool temp. Wait until pool needs heat.
SH	Temperature sensor	Failure	Call Pool Service Provider.
OP	Temperature sensor	Failure	Call Pool Service Provider.
888	Thermostat reset	Normal operation	Temporary display. Shows for 1-2 seconds when the unit is first turned on.
rhd		Remote device is controlling the unit.	Refer to owner's manual of the remote device.
			If a remote device is not connected. Call Pool Service Provider.
PST	Push button stuck	Release button is stuck.	If button does not release. Call Pool Service Provider.
PNL	Control not receiving data from panel	Control communication problem.	Call Pool Service Provider.
CEL	Panel not receiving data from control	Control communication problem.	Call Pool Service Provider.
CHC	Board self-check error	Board Failure	Call Pool Service Provider.
dEF	Defrost Mode	Frost build up on evaporator coil.	No action required. Unit is defrosting automatically.
cOP	Coil Sensor	Sensor Failure	Call Pool Service Provider
cSH	Coil Sensor	Sensor Failure	Call Pool Service Provider

USE ONLY HAYWARD GENUINE REPLACEMENT PARTS

Heat Pump Replacement Parts Diagram

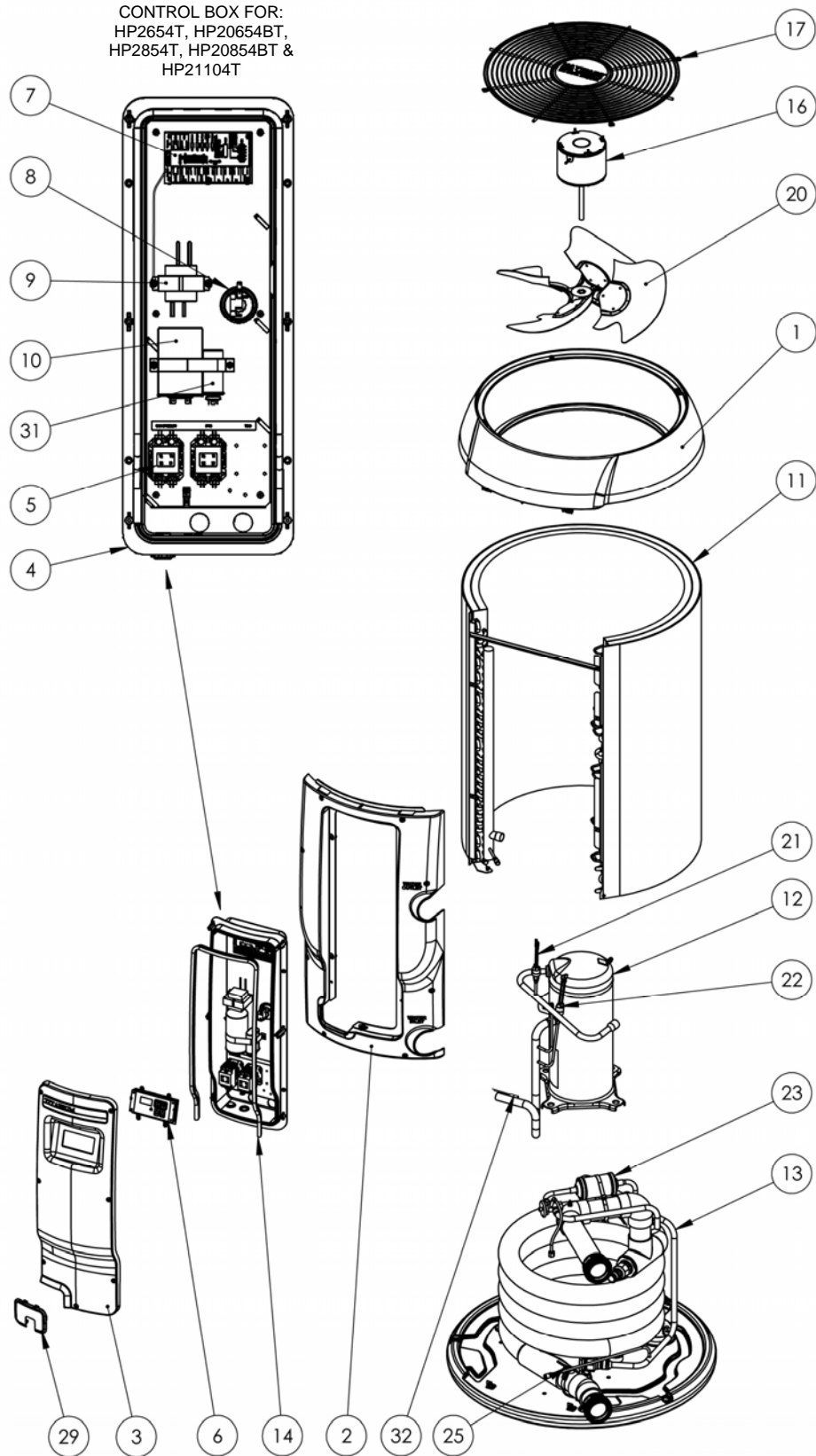

USE ONLY HAYWARD GENUINE REPLACEMENT PARTS

Heat Pump Replacement Parts List

Item	Part description	HP20654T	HP20654BT	HP20854T	HP20854BT	HP21104T
1	FAN TOP	HPX01023502	HPX01024821	HPX01023502	HPX01024821	HPX01023502
2	SIDE PANEL	HPX01023503	HPX01024822	HPX01023503	HPX01024822	HPX01023503
3	CONTROL BOX COVER	HPX01023504				
4	CONTROL BOX	HPX01023505				
5	CONTACTOR	HPX1985				
6	CONTROL BOARD ASSY	HPX26024139				
7	INTERFACE BOARD	HPX11024130				
8	WATER PRESSURE SWITCH	HPX2181				
9	TRANSFORMER	HPX11023693				
10	CAPACITOR	HPX11024270	HPX11024272		HPX11024743	
11	BENT COIL with GUARD	HPX24024238				HPX24024241
12	COMPRESSOR	HPX11024257	HPX11024204		HPX11024203	
13	CONDENSER	HPX24024712				HPX24024210
14	COVER GASKET	HPX05023549				
15	HPC CABLE (NS)	HPX10023517				
16	FAN MOTOR, 1/3 HP	HPX11023564				
17	FAN GUARD	HPX01023561				
18	COMPRESSOR BLANKET (NS)	HPX02024108				
19	-	-				
20	FAN BLADE	HPX15024321				
21	REPLACEMENT HP SWITCH	HPX11024258				
22	REPLACEMENT LP SWITCH	HPX11024259				
23	EXPANSION VALVE ASSY	HPX15024216	HPX15024215		HPX15024214	
24	-	-				
25	TEMPERATURE SENSOR	HPX2169				
26	SCREW REPLACEMENT KIT (NS)	HPXSCRKIT1				
27	COMPRESSOR MOUNT KIT (NS)	HPX0054				
28	COMPRESSOR EL. PLUG (NS)	HPX10024732	HPX10024289			
29	ELECTRICAL ENTRY PLUG	HPX01023760				
30	-	-				
31	FAN RUN CAPACITOR	HPX11024151				
32	DEFROST SENSOR	HPX11024169				

USE ONLY HAYWARD GENUINE REPLACEMENT PARTS

HAYWARD® HEAT PUMP POOL HEATER LIMITED WARRANTY

The HAYWARD heat pump pool heater is warranted to be free of defects in materials and workmanship for a period of two (2) years for parts and (1) one year for labor. In the state of Florida, warranty labor is covered for (2) years. This warranty is applicable to the original location and owner only and is not transferable. The *compressor* component has a five (5) year limited warranty with parts and labor warranted the first two (2) years and parts only warranted in years three (3), four (4) and five (5). The *titanium tube* component of the heat exchanger has a ten (10) year warranty. HAYWARD will not void this warranty due to improper pool chemistry. This warranty is valid only if the product is installed according to the HAYWARD specifications.

This warranty does not include refrigerant or other expendable materials, or services such as inspection, maintenance, or unnecessary service calls due to erroneous operational reports, external valve position, or electrical service. It also does not include the repair of damage due to negligence, accident, freezing, installation in corrosive environments or atmospheres, conditions beyond the normal intended use of the unit, or acts of God. This warranty is void if the product is repaired or altered in any way by any persons or agencies other than those authorized by HAYWARD, and is in lieu of all other warranties, expressed or implied, written or oral. There are no implied warranties of merchantability or fitness for a particular purpose that apply to this product. This warranty applies to the continental USA, Hawaii, Alaska and Canada. For warranty outside these locations please visit www.haywardnet.com.

At its option, HAYWARD will replace or repair any HAYWARD part that proves defective if such parts are returned to our factory, freight collect, within the warranty period. It is agreed that such replacement or repair is the exclusive remedy available from HAYWARD. Unless authorized by HAYWARD and performed by a factory authorized service center, HAYWARD is not liable for any labor involved in the removal of defective parts or the installation of replacement parts. HAYWARD is not liable for damages of any sort whatsoever, including incidental and consequential damages. Parts returned and services performed under terms of this warranty must be approved by HAYWARD. All parts returned under terms of this warranty will be repaired or replaced and returned transportation charges prepaid, by best and most economical means.

INTERNATIONAL WARRANTY

The HAYWARD heat pump pool heater is warranted to be free of defects in materials and workmanship for a period of one (1) year. The compressor is warranted for two (2) years, and the titanium tube component of the heat exchanger has a ten (10) year warranty.

The above coverage begins from the date of purchase, or sixty days after product manufacture date and applies only if the product is installed according to the HAYWARD specifications. This warranty does not include the repair of damage due to negligence, accident, freezing, installation in corrosive environments or atmospheres, conditions beyond the normal intended use of the unit, or acts of God. There are no implied warranties of merchantability or fitness for a particular purpose that apply to this product.

These warranties apply to units shipped after October 1, 2008

Hayward Pool Products, Inc.
620 Division Street
Elizabeth, NJ 07207

Retain this Warranty Certificate in a safe and convenient location for your records

USE ONLY HAYWARD GENUINE REPLACEMENT PARTS

▼ DETACH HERE: Fill out bottom portion completely and mail within 10 days of purchase/installation.



Heat Pump

Warranty Card Registration

Register your warranty on-line at www.haywardnet.com

Please print clearly.

First Name _____ Last Name _____

Street Address _____

City _____ State _____ Zip _____

Phone Number _____ Purchase Date _____

E-mail address _____

Serial Number (10-17 Digit Number)

--	--	--	--	--	--	--	--	--	--	--	--	--	--	--	--	--	--	--	--

Model Number _____

Pool Capacity _____ (U.S. Gallons)

Please include me on all e-mail communications regarding Hayward equipment or promotions.

Mail to: Hayward Industries, Inc. 620 Division Street, Elizabeth, NJ 07207.
Attn: Warranty Dept. or Register your warranty on-line at www.haywardnet.com

Years pool has been in service	
<input type="checkbox"/> 1 year or less	<input type="checkbox"/> 2-3 <input type="checkbox"/> 4-5 <input type="checkbox"/> 6-10 <input type="checkbox"/> 11-15 <input type="checkbox"/> >16
Purchased from _____	
<input type="checkbox"/> Builder	<input type="checkbox"/> Retailer <input type="checkbox"/> Pool Maintenance <input type="checkbox"/> Internet/Catalog
Company name _____	
Address _____	
City _____	State _____ Zip _____
Phone _____	
Type of Pool:	
<input type="checkbox"/> Concrete/Gunite	<input type="checkbox"/> Vinyl <input type="checkbox"/> Fiberglass <input type="checkbox"/> Other _____
<input type="checkbox"/> New Installation	<input type="checkbox"/> Replacement
Installation for:	
<input type="checkbox"/> Inground	<input type="checkbox"/> Aboveground <input type="checkbox"/> Spa

HAYWARD Pool Products
One source. Every pool.

WCR000000007

USE ONLY HAYWARD GENUINE REPLACEMENT PARTS



Pomona, CA Clemmons, NC Nashville, TN
Tel: 908.351.5400 www.haywardpool.com